

POWDER FEED HOPPER

The **Ultra-Static™** stainless steel hopper is designed for fast and easy color change with easy break-apart construction. The snap-lock latches allow the removal of the membrane and air plenum pan in seconds for a contamination free color change.

DESIGN FEATURES

- **Hopper Capacity:** Nominal 100 lb. (140 liter) capacity
- **Stainless Steel Hopper Body:** Formed and welded easy to clean design
- **Hinged Lid Assembly:** Removable stainless steel lid assembly with handle and 2" dia. vent hose outlet. The lid mounts up to (8) pump mounts located to the rear of the lid or on the sides of the hopper mounted vertically with 90 deg. Pick-up Tubes.
- **Air Plenum Pan:** Powder coated, break-apart construction with draw latches
- **Caster Mounted:** Locking double-wheel swivel casters for easy maneuvering
- **Fluidizer Membrane:** Removable and gasketed 1/2" membrane.
- **Pump Mounts & Pick-Up Tubes:** Specify quantity and type of pumps used.

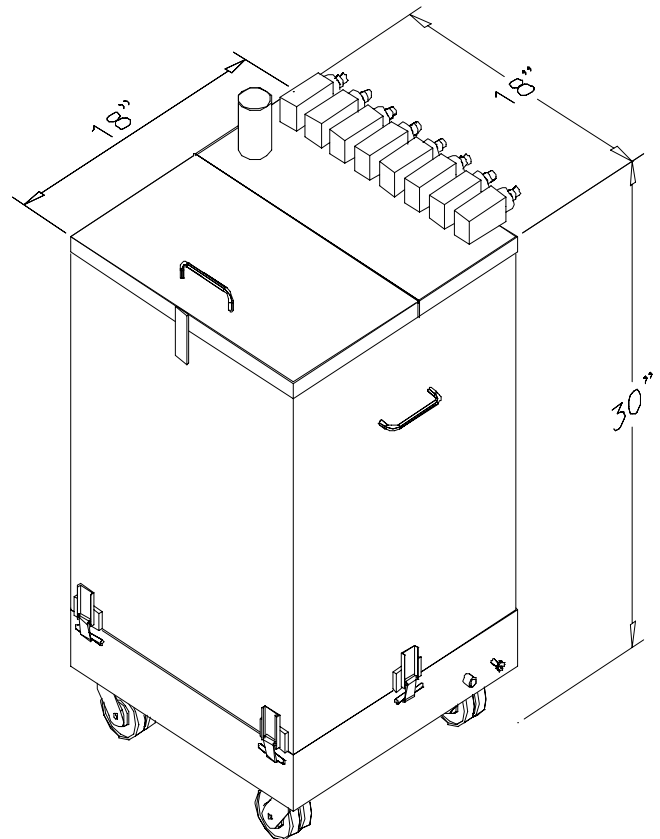

BREAK-APART FEATURE

**ISOMETRIC DETAIL OF HOPPER
WITH TOP MOUNTED PUMPS
AND 2" DIA. VENT SLEEVE**