

POWDER PARTS, INC.

POWDER FEED HOPPER

The **Ultra-Static™** 220 lb. stainless steel hopper is designed for automatic lines. The hopper latches to the booth for direct vent or through a hose. The break-apart construction facilitates cleaning or changing the membrane. The pumps are top mounted.

DESIGN FEATURES

- ❑ **Hopper Capacity:** Nominal 220 lb. (300 liter) capacity, custom made to order
- ❑ **Stainless Steel Hopper Body:** Formed and welded easy to clean design
- ❑ **Modular Lid Assembly:** Hinged and gasketed cover for easy powder access
- ❑ **Hopper Options:** Customize the hopper to match your needs or existing models
 - Hopper Vent designs: 2-1/2" dia. vent hose outlet or direct vent to booth collector
 - Powder Level Probe Wells: Top or side mounted dry well for sensor probes
 - Powder Receiver: Separator for extracting compressed air from transferred powder
 - Rotary Screener Hose Intake Flange: Connects hopper to Screener
- ❑ **Pump Mount Adapters:** The lid accommodates up to (16) pump mounts
- ❑ **Break-Apart Construction:** Powder coated air plenum with bolt style latching
- ❑ **Caster Mounted:** Various swivel caster options for easy maneuvering
- ❑ **Fluidizer Membrane:** Removable and gasketed 1/2" membrane
- ❑ **Pump Mounts with Pick-Up Tubes:** Specify quantity and brand of pumps used

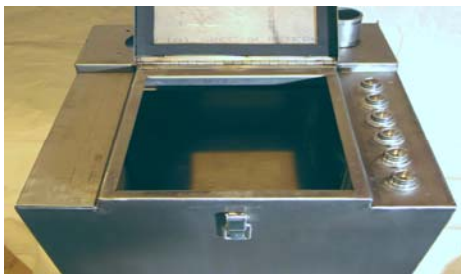

ACCESS LID DETAIL

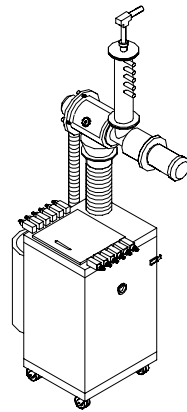

SCREENER OPTION

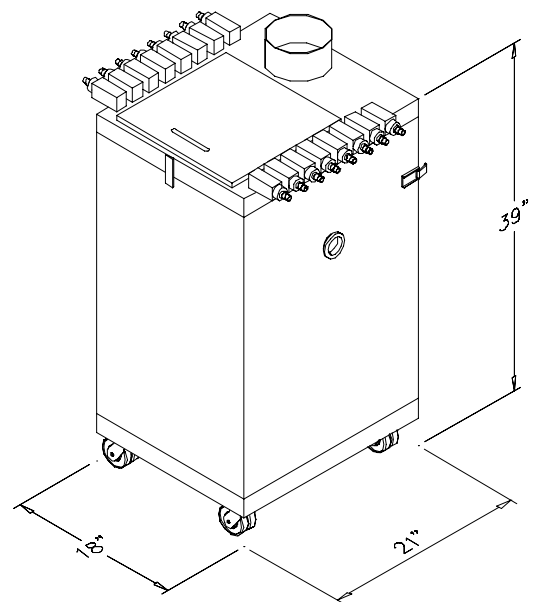

SCHEMATIC DRAWING



HOPPER ASSEMBLY



INTAKE TUBES



BREAK-APART PAN AND CASTERS